

SunScape®

Installation and Important Safety Instructions

Congratulations on your purchase of a SunScape™ lateral arm awning. Another 100% American made 1-800Awnings.com product. SunScape™ is completely pre-assembled and factory tested; it is specifically designed for easy installation.

Before beginning, please familiarize yourself with the components of the awning. It will save you time in the long run.

Glossary of terms:

Roller tube; Long round tube on which the fabric is rolled.

Support tube; Long square tube below the roller tube to which the arms are attached.

Front rail; the long rail to which the fabric, valance and the leading end of arms are attached.

Arm clamp/shoulder joint; the part of the arm where it attaches to the support tube.

Bearing end plate; The part bolted on the end of the support tube to which the roller tube and gear or motor is attached.

Warning! The arms are under high spring tension. Do not detach them from the front rail or support tube unless they are fully extended or securely tied closed. Do not cut the plastic sleeve on an arm before installing the fabric.

Find the mounting brackets: they will be one of the three types designed specifically for your installation. Brackets #418 and #419 are for wall mount installation. Bracket #420 is used for soffit mounting.

The length of the awning determines the number of brackets. A 6 ft. long awning will have two brackets, a 12 ft., three, a 16 ft., four, and a 21 ft., six brackets. Use all brackets for secure mounting.

TOOLS REQUIRED

Electric drill, 1/8" and 1/4" drill bit, two 9/16" and two - 1/2" wrenches or sockets, #1 Phillips screwdriver, stud finder (for wood frame construction), 1' and 4' levels, and chalk line. A heavy duty mason drill with a carbide bit is required to install brackets on masonry walls.

LOCATING THE BRACKETS

Proper location of the brackets is the most important aspect of the SunScape™ mounting. They must be fastened to studs, joists, headers or other major structural members. Even a moderate wind exerts great force on the awning and mounting brackets. This is why it is most important that all SunScape™ mounting brackets be fastened properly and securely. Proper location will also make it easier to insert the support tube when hanging the awning.

When only two brackets per awning are provided, the mounting brackets must be located within 12" of center between arm clamp and the bearing end plate. If a third mounting bracket is required, it must be located at a point on the support tube within 12" of center between the two arm clamps. When two brackets per arm are provided, locate each bracket within 12" of center of the arm clamp and the bearing end plate. The second bracket must not be more than 14" from the inside of the arm clamp on the support tube.

To determine the proper height of the mounting brackets refer to page three of these installation instructions. Next find the projection on the pitch chart which matches that of the one you are installing. Add the number of inches that are needed from the pitch chart to the height at which you prefer the front rail when the awning is fully extended. This is considered the optimum installation height but not always obtainable due to low roof heights. Next, snap a level chalk line along the wall at the height you have determined to be the top of the bracket. Make a mark on the wall at the end points of the awning and at the arm clamps.

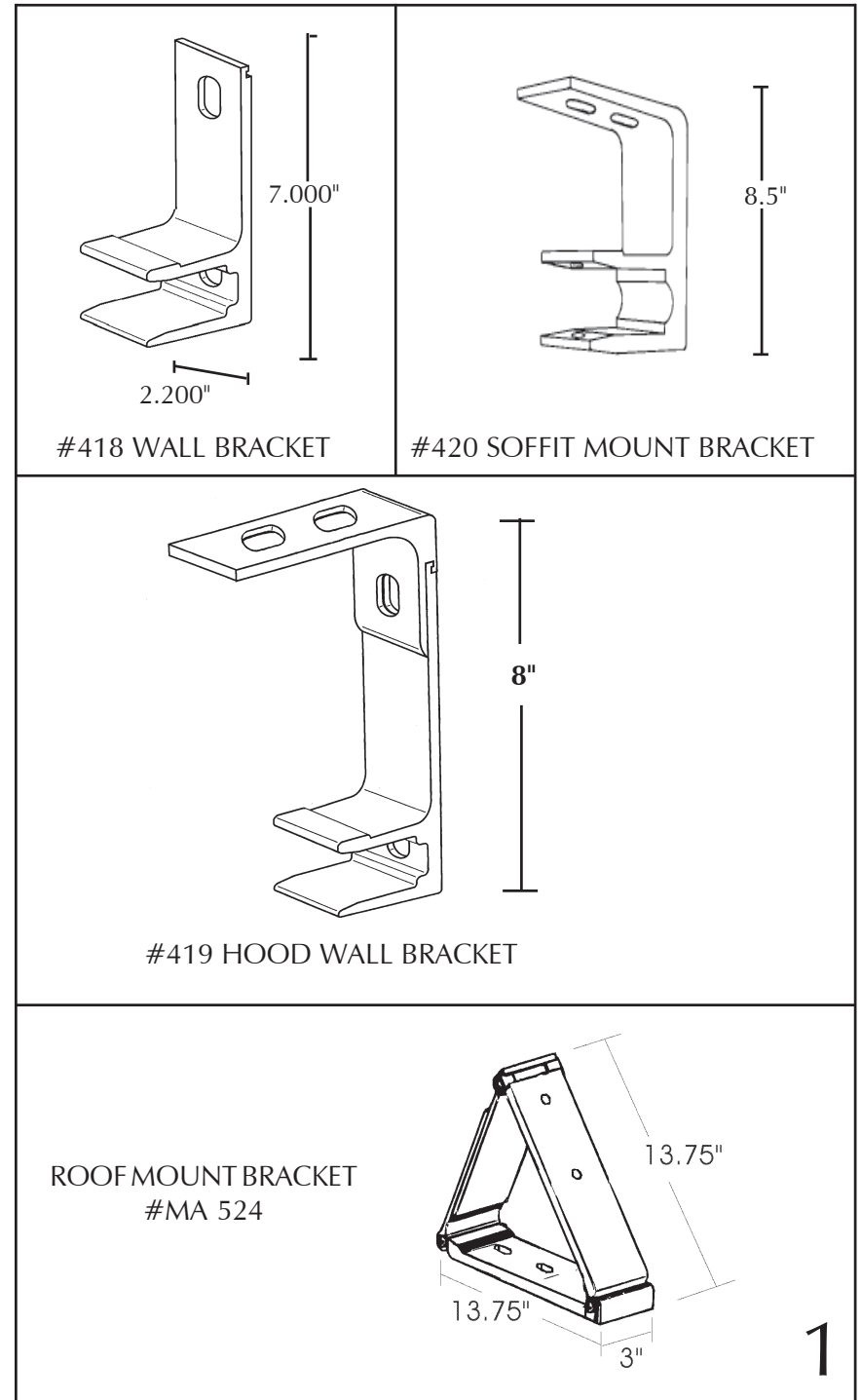

INSTALLING THE BRACKETS ON WOOD FRAMED WALLS

You must first locate the studs, joists or header in the area in which the bracket must be installed as explained earlier in LOCATING THE BRACKETS. To find the stud or joists, measure from the edge of a window or door to the approximate area where the bracket is being installed, then on the inside of the wall measure from the same window or door to the same area, and with a stud finder locate the stud and transfer your dimension to the outside wall. Next drill horizontally a series of 1/8" holes approximately 1" below the chalk line at the mounting point to locate the edge of the stud or framing. Then measure to the center of the stud and draw a 7" vertical level line. **(Never guess to the center of the stud.)**

Position the bracket holes, centered over the vertical plumb line and the top of the bracket, even with the horizontal chalk line. Mark both bracket holes and drill 1/4" pilot holes square to the wall 2 1/2" into the stud or joist. This will prevent the framing from splitting while installing the lags. Use a silicone sealant to fill all of the 1/8" holes made while locating the studs. If done properly the mounting bracket will cover all the 1/8" holes. Install the bracket with a 3/8" diameter lag using a length that will penetrate the framing 2 1/2" to 3". Use a flat washer under the head of the lag. Make sure not to over tighten the lags; doing so may split the wood framing or weaken the lag.

“SOFT” WALLS (SHINGLES, VINYL, OR ALUMINUM SIDING, CLAPBOARDS)

This type of construction requires the use of spacers or shims under the brackets to insure that they are level and to avoid crushing the soft material when the brackets are tightened. It is not advisable to cut openings in the siding and recess the brackets, since this will not allow sufficient clearance for the lateral arm clamps (#1). The best way to deal with a “soft” wall is with spacer blocks cut out of pressure treated lumber, 1" or 1 1/2" thick by the width and height of the mounting bracket. Use a spacer for each bracket. After

locating the studs for each mounting bracket, place the spacer on the siding in the exact location where your bracket is to be mounted. Trace all four sides of the spacer on the wall. Using a small circular saw to cut the siding, remove the cut piece of siding and place the spacer into the opening and against the sheathing to assure the proper fit. Drill two 1/2" diameter holes into the spacer to align with bracket holes. Drill the two 1/4" pilot holes square into the framing for your brackets. Insert the spacer into the opening and place the mounting bracket on top and lag both into wall. Be sure to seal around the spacer and the siding. An alternative method where the “soft” wall is flat, is to lag a 2" x 8" or 2" x 10" header the length of the awning, at the proper height, and bolt the brackets, to it. With clapboards or shingles, tapered shims may also be used under the brackets. Important: If you find rotten wood or experience poor fastening, you will have to use the alternative method defined above to assure proper bracket installation.

BOWED WALLS

You may find when stretching a chalk line from one bracket to another, that the wall is bowed. In this case, either the end brackets or the intermediate brackets must be spaced outward from the wall by shims to insure proper alignment.

MASONRY OR CONCRETE WALLS

Our #418 and #419 mounting brackets are also used when installing the SunScape™ on masonry and concrete walls. Follow the same procedure to locate each bracket as earlier explained in LOCATING THE BRACKETS. Always use caution when choosing masonry or concrete fasteners to mount the brackets. When mounting on any masonry or concrete surface be certain that the wall has not deteriorated. If this is the case through-bolting may be necessary. When mounting on typical hollow core block walls you will need to through-bolt or use special epoxy fasteners designed for hollow block. Due to the many variations of masonry installation, we strongly recommend you call your local fastener supplier for their

recommendations on choosing the proper concrete anchors.

ROOF MOUNT INSTALLATION

Locate the center of each of the roof rafters as explained in LOCATING THE BRACKETS, then place the roof bracket approximately 1" back from the edge of the roof.

Note: some roof edges can be severely rotted and the bracket may have to be moved accordingly or the framing replaced.

Align the elongated holes of the lower plate over the rafters and mark their position. Carefully pilot drill a 1/4" hole at a 90 degree angle into the rafter where marked, and apply a 1/2" high bead of silicone sealant in a 2" circle around each hole. Apply a 1/2" bead of silicone sealant to the underside of the roof bracket, along the left, right and top edges to form a horseshoe of sealant leaving the bottom open.

Bolt all brackets to the roof using a 3/8" diameter lag and a length that will penetrate the rafter 2 1/2" to 3". Refer to "Locating the Brackets" for details on lag selection and tightening. Adjust the roof mount bracket angle accordingly and fasten the adjusting plates.

Bolt a continuous pressure treated 2" x 8" along the top edge of the roof mount brackets. Using 1/2" diameter carriage bolts fasten all SunScape™ mounting brackets in their proper location to the 2" x 8" lumber with 1/2" carriage bolts. You can install the SunScape™ mounting brackets directly to the roof mount brackets, eliminating the need for a 2" x 8" header board. But you will get better weather protection on the back side of the awning when using the 2" x 8".

INSTALLING THE OPTIONAL HOOD

It is important to install the hood before the awning. Using the 5/16" jam nuts provided, slide the correct number of nuts into the extruded slots of the hood. The number of nuts in each slot should correspond to the number of brackets. Be sure to use two nuts per bracket. Carefully lower the hood onto the brackets and align the nuts to the appropriate holes. Then, using the supplied phillip pan head stainless steel bolts, carefully tighten the hood to the brackets. Attach the hood end covers to the ends of the hood using the #6 phillip head sheet metal screws. (3 screws per end cover)

INSTALLING THE AWNING

Leave the retaining straps in place (if provided), until installation has been completed. With proper help, place the awning into position so the ends line up with the points marked on the ceiling or wall. Insert the 3/8"-16x21/2" hex head bolts with flat washers into the brackets. Be sure to install a washer under the bolt head and then tighten securely. The retaining bolts should slip in easily. If not, slight pressure on the support tube should permit insertion. If there is still a problem, loosen the bracket mounting bolts until the retaining bolts fit, then retighten all bolts.

AWNING ADJUSTMENT AND PITCH RECOMMENDATIONS

After the awning has been installed, making sure all bolts have been tightened and packing materials removed, extend the awning to its full projection. It is normal for the folding arms to be slightly angled.

Setting the correct pitch is one of the most important details. Extend the awning to its fullest projection, keeping the fabric as taut as possible. Using a 4' level or larger, place the level on the bottom of the front rail and set the pitch of the fabric to the pitch chart on this page of these instructions. If there are ever questions regarding this procedure, call the factory for additional information.

Our shoulder joint is designed for easy adjustment. All that is needed is a 1/2" wrench and a 1/2" socket. Loosen but do not remove the two nuts located on the side of the shoulder joint assembly. With your socket turn the bolt head located on the top front portion of the shoulder joint counter clockwise to increase the angle of

pitch to the desired position. Refer to the pitch chart on this page for minimum pitch recommendations. Adjust all arms until the front rail is level. **Securely** tighten the two nuts located on the side of the shoulder joint

SUNSCAPE™ WITH ELECTRIC MOTOR

Mount the awning in the same manner as a manually operated awning. An electrical diagram, supplied with the motor switch, will indicate the proper connections to 120-volt AC service. Do not adjust the motor limit switches unless the awning pitch has been significantly increased or decreased from the factory settings. The factory preset the in and out internal motor limit switches. When significantly changing the pitch, the fabric may be too tight or too loose when the awning is extended or retracted. Before wiring two or more Somfy motors together please contact 1-800Awnings.com for important wiring information.

NOTE: If you are experiencing difficulty or do not clearly understand these installation instructions, please call 1-800Awnings.com for assistance. (800)-296-4647

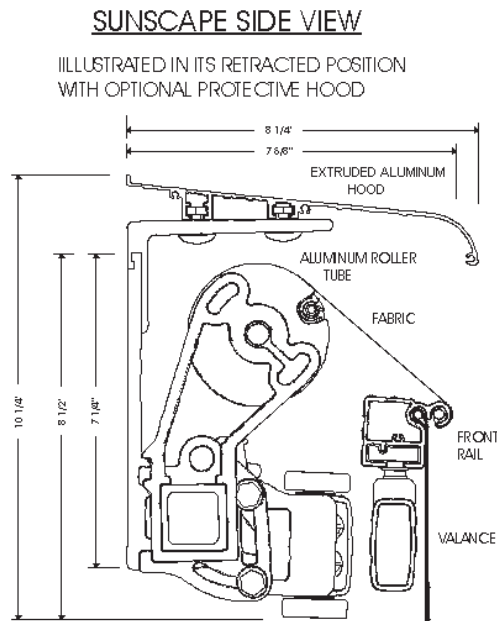

Sunscape Minimum Pitch Recommendations

Note: The drop is defined as the difference between the top of the roller tube and the top of the front rail.

